

## Product Information

### Type 8322 Pincer Grips, Fmax 5 kN / 10 kN

CTA: 39789 32563

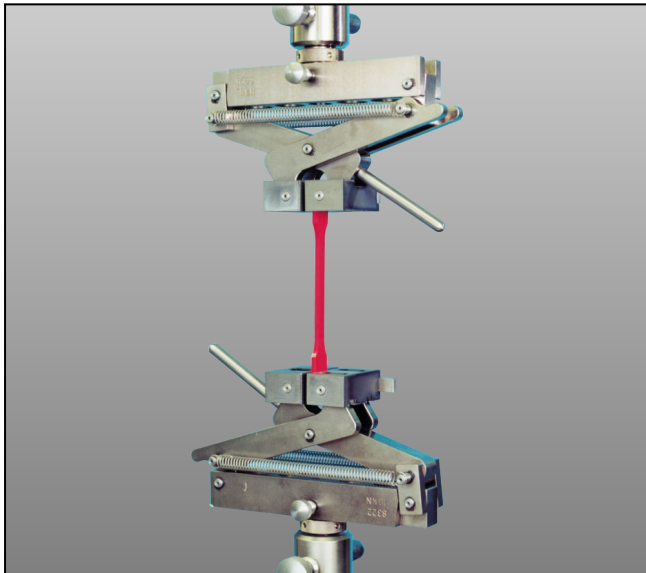

Type 8322 pincer grips, Fmax 5 kN

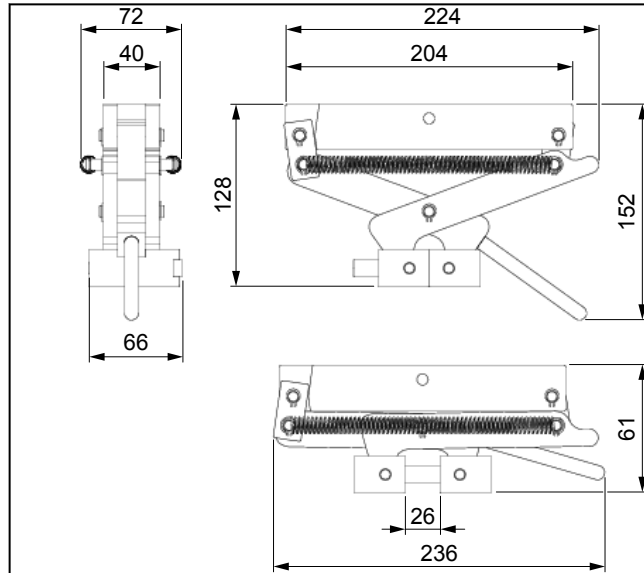

Type 8322 pincer grips, general view

#### Applications

- Specimen material: elastomers, soft plastics
- Specimen shape: flat specimens
- Type of loading: tensile

#### Function description

The pincer grip is a double actuator grip. The pincer grip is opened and closed via a clamping lever.

The prestressed spring holds the specimen grip open for specimen insertion. If the specimen grip is closed, the prestressed spring generates the required gripping force.

The gripping force is increased proportionally by the pincer principle as the tensile force increases. This

ensures automatic retightening for specimens prone to shrinkage.

The grips are supplied with permanently fitted jaws.

#### Advantages and features

- Secure specimen gripping through gripping force increasing proportionally to tensile force
- The lateral mobility of the pincer grips allows specimens always to be loaded centrally to the test axis.
- Ergonomic, open design for fast, easy specimen insertion and clamping
- The grips are easy to operate in a temperature chamber and reach the test temperature quickly thanks to their very low mass.

## Product Information

Type 8322 Pincer Grips, F<sub>max</sub> 5 kN / 10 kN

### Technical data

Item No.	069915	069914	314615	314950	
Type	8322	8322	8322	8322	
Operating principle/identification	Pincer action, auto. Retightening	Pincer action, auto. Retightening	Pincer action, auto. Retightening	Pincer action, auto. Retightening	
Test load F <sub>max</sub>	5	5	10	10	kN
Dimensions					
Height	128	128	128	128	mm
Height (when open)	88	88	88	88	mm
Width	224	224	224	224	mm
Width (when open)	236	236	236	236	
Depth	66	66	66	66	mm
Opening width, max.	26	26	26	26	mm
Gripping of the specimen	The specimen must be gripped with at least 3/4 of the jaw height.				
Weight (with jaws), approx.	3.6	3.6	3.6	3.6	kg
Connection, stud	Ø 20	Ø 20	Ø 20	Ø 20	mm
Ambient temperature	-40 ... +250	-40 ... +250	-40 ... +250	-40 ... +250	°C
Scope of delivery	2	1	2	1	pieces
<b>Jaws supplied</b>					
Surface	Steel, St <sup>1)</sup> 2 mm	Steel, St <sup>1)</sup> 2 mm	Steel, St <sup>1)</sup> 2 mm	Steel, St <sup>1)</sup> 2 mm	
Gripping area (H x W)	26 x 60	26 x 60	26 x 60	26 x 60	mm
Hardness	700 HV	700 HV	700 HV	700 HV	

1) St= saw tooth