

Product Information

Wedge grips type 8502, Fmax 100 kN

CTA: 43129 39911

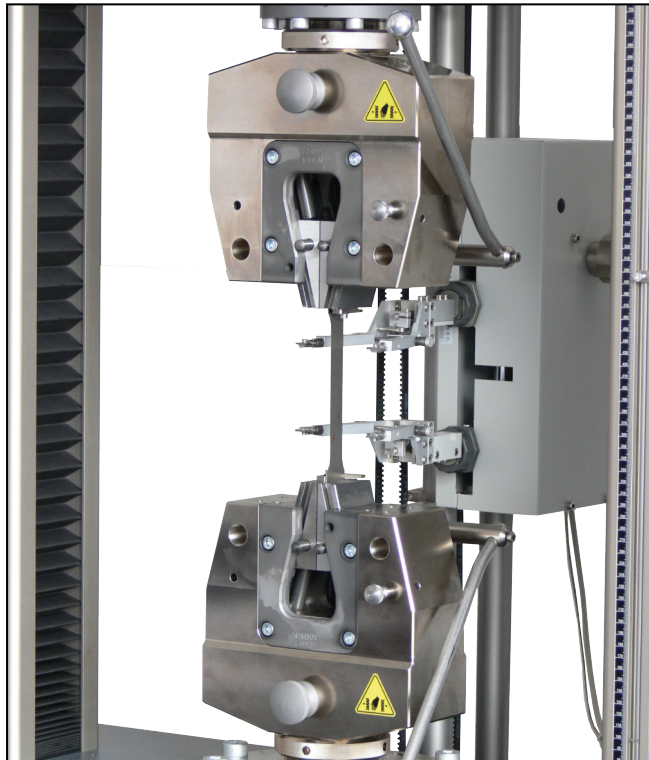

Wedge grips type 8502, Fmax 100 kN

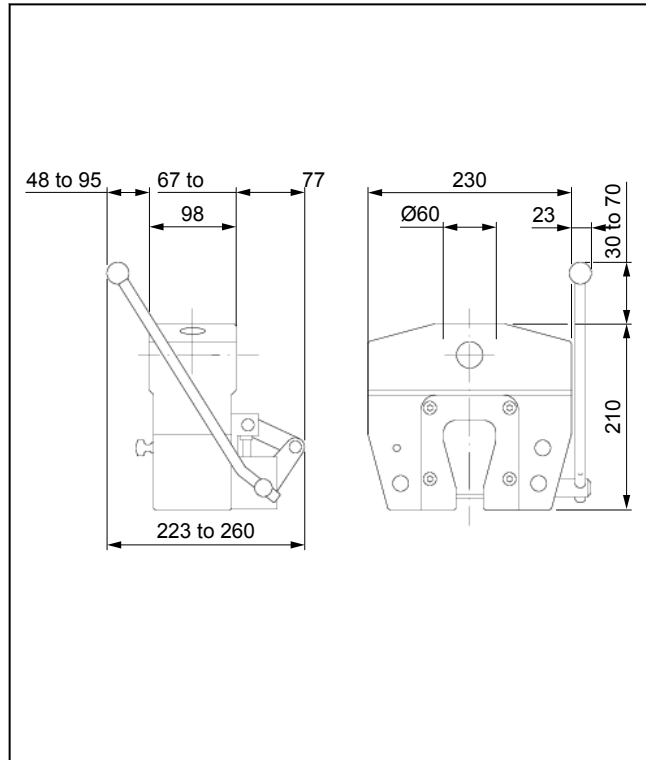

Wedge grips type 8502 Fmax 100 kN, general view

Applications

- Specimen material:
metals, plastics, wood
- Specimen shape:
round and flat specimens
- Type of loading:
tensile

Function description

Wedge grips are symmetrically closing specimen grips. Opening and closing plus application of closing force prior to the test is via a lever.

To generate the closing force the wedge grips are equipped with a pre-loaded spring. The gripping force is generated via wedge action and is proportional to the tensile force. The ratio is determined by the wedge angle.

Both upper and lower grips are equipped with a locking device which holds the grips in an open position to allow insertion of the specimen.

In tests with these grips extensometers are used for accurate strain measurement.

Small load cells, specimen grips and test fixtures can be attached via a mounting unit.

Advantages and features

- These wedge grips represent a quick, cost-effective solution, for example for quality assurance.
- The grips always close symmetrically to the tensile axis regardless of specimen thickness.
- Large clamping length allows sensitive specimens to be gripped gently at all times, thereby avoiding jaw breaks.
- The lever is locked when the grips are open, enabling rapid specimen changes.
- Markings on the jaws allow easy specimen centering.
- Centering stops enable fast, accurate specimen centering.
- Ergonomic, open design for fast, easy specimen insertion and clamping
- Time-saving - small load cells, specimen grips and test fixtures can be attached via optional mounting unit/T-slot system without removing the grips.
- Large opening width accommodates a wide range of applications.

PI 371 0918

Product Information

Wedge grips type 8502, F_{max} 100 kN

Technical data

Type	8502		
Item No.	320129		
Test load F _{max}	100		kN
Dimensions			
Height	210		mm
Width	253		mm
Depth	88		mm
Depth with actuation lever	291		mm
Specimen gripping	The specimen must be gripped over at least 2/3 of the jaw height.		
Weight per grip unit, approx.	27		kg
Connection, stud	Ø 60		mm
Ambient temperature	-40 to +250		°C
Scope of delivery	2		pieces

Accessories required

Jaws and jaw mountings 1x required)

Scope of delivery: 1 set (= 4 pieces)

Range of application	Version	Specimen thickness [mm]	Gripping area (H x W) [mm]	Ambient temperature [°C]	Hardness	Item No.
Soft non-ferrous metals and steels, metal and plastic pipes with plugs, reinforced plastics	steel, fsc ¹⁾ 0.4 mm	0 to 21	80 x 60	-40 to +250	61 HRC	320131
Soft non-ferrous metals and steels, metal and plastic pipes with plugs, reinforced plastics	steel, fsc ¹⁾ 0.75 mm	0 to 21	80 x 60	-40 to +250	61 HRC	320133
Soft non-ferrous metals and steels, metal and plastic pipes with plugs, reinforced plastics	steel, fsc ¹⁾ 1.25 mm	0 to 21	80 x 60	-40 to +250	61 HRC	320135
Soft non-ferrous metals and steels, metal and plastic pipes with plugs, reinforced plastics	steel, fsc ¹⁾ 0.4 mm	11 to 30	60 x 60	-40 to +250	61 HRC	318797
Soft non-ferrous metals and steels, metal and plastic pipes with plugs, reinforced plastics	steel, fsc ¹⁾ 0.75 mm	11 to 30	60 x 60	-40 to +250	61 HRC	318799
Soft non-ferrous metals and steels, metal and plastic pipes with plugs, reinforced plastics	steel, fsc ¹⁾ 1.25 mm	11 to 30	60 x 60	-40 to +250	61 HRC	318801
Round specimens (prism jaws)	steel, st ²⁾ 1.5 mm	Ø 4 to 10	80 ³⁾	-40 to +250	61 HRC	320137
Round specimens (prism jaws)	steel, st ²⁾ 1.5 mm	Ø 10 to 21	80 ³⁾	-40 to +250	61 HRC	320139

Product Information

Wedge grips type 8502, Fmax 100 kN

Range of application	Version	Specimen thickness [mm]	Gripping area (H x W) [mm]	Ambient temperature [°C]	Hardness	Item No.
Round specimens (prism jaws)	steel, st ²⁾ 1.5 mm	Ø 21 to 30	60 ³⁾	-40 to +250	61 HRC	318805
High-tensile wire, glassfiber-reinforced plastics, carbon fiber materials	carbide, dp ⁴⁾ 0.7 mm	0 to 21	45 x 30	-40 to +250	1250 HV	317392 ⁵⁾
High-tensile wire, glassfiber-reinforced plastics, carbon fiber materials	carbide, dp ⁴⁾ 0.7 mm	0 to 6	70 x 34	-40 to +250	1250 HV	318643 ⁶⁾⁷⁾

- 1) Fsc = fish scale
- 2) St= saw-tooth
- 3) Prism jaws (with V-groove), hence clamping length specified here
- 4) Dp = diamond pattern
- 5) Required: jaw mountings, dp, 0.7 mm, gripping area 45 x 30 mm
- 6) Requires: jaw mountings, dp, 0.7 mm, gripping area 70 x 34 mm
- 7) The jaws must only be changed using a tool.

Jaw mountings

Description	Item number
Jaw mounting for carbide jaws, dp ¹⁾ 0.7 mm, gripping area 45 x 30 mm, incl. centering stop Caution: restricted Fmax = 50kN!	320143
Jaw mounting for carbide jaws, dp ¹⁾ 0.7 mm, gripping area 70 x 34 mm, incl. centering stop	320145

- 1) Dp = diamond pattern

Optional accessories

Description	Item number
Centering stops for centered clamping of specimen with variable height adjustment Scope of delivery: 2 pieces, sufficient for 2 grip units	318793
Mounting kit for T-slotted shoe connector	320141
T-slotted shoe connector (mounting kit required)	314054