

Product Information

Wedge screw grips Type 8406 Fmax 50 kN, Type 8506 Fmax 100 kN, 150 kN and Type 8507 Fmax 250 kN, manual

CTA: 43071 40068

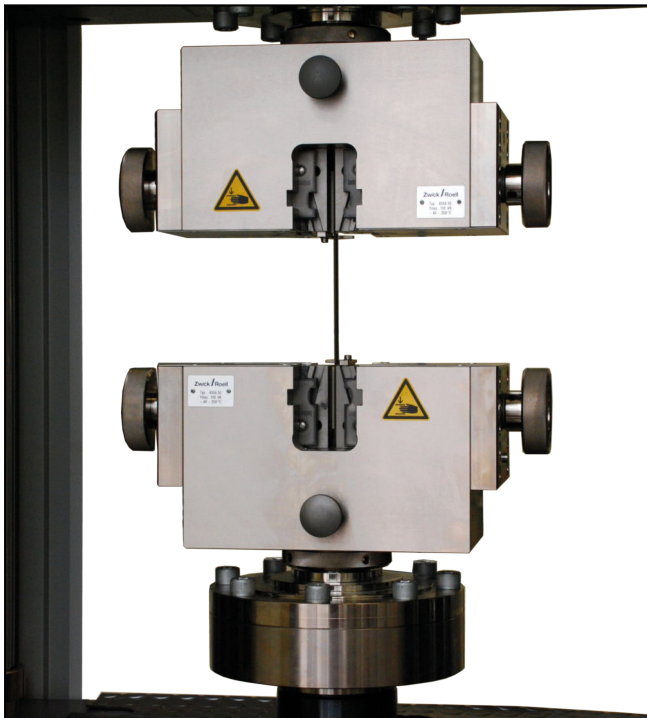

Type 8506 wedge-screw grips (manual), Fmax 150 kN

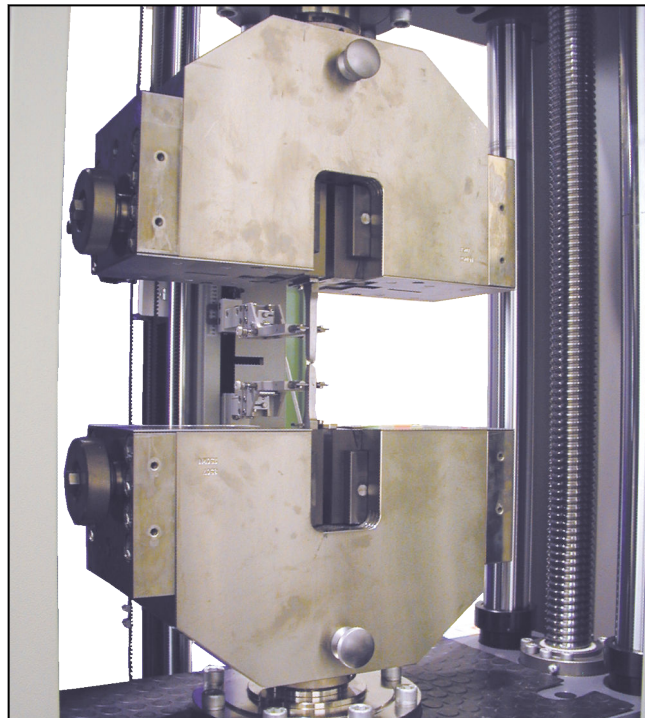

Type 8507 wedge-screw grips (manual), Fmax 250 kN

Applications

- Specimen material
Metals, plastics
- Specimen shape
Round and flat specimens
- Type of loading
Tensile

Function description

A handwheel is used to open and close the wedge screw grips, as well as apply closing force before the test. Switchable synchronization allows the grips to be set both symmetrically and asymmetrically.

The gripping force is generated via wedge action. The gripping force is proportional to the tensile force. The ratio is determined via the wedge angle.

A slot for the insertion of the T-slotted system is incorporated into this specimen grip type.

These specimen grips are also available in motorized versions.

Advantages and features

- Switchable synchronization enables symmetrical and asymmetrical specimen testing.
- Fast and easy insertion of specimen is enabled due to the ergonomic and open design.
- The jaws can be changed quickly and easily without tools if the application changes. The jaws are thus automatically centered.
- The specimen grip can be easily operated in the temperature chamber and quickly reaches its test temperature due to its low mass.
- accurate test results combined with a high number of cycles due to the adjustable centering stops for flat specimens
- You save time, by quickly and easily adapting small specimen grips and test tools to large specimen grips via the T-slotted system. Precise alignment ensures reliable test results.

Product Information

Wedge screw grips Type 8406 F_{max} 50 kN, Type 8506 F_{max} 100 kN, 150 kN and Type 8507 F_{max} 250 kN, manual

Technical data

Item No.	1091222 ¹⁾	1097236 ¹⁾	1097237 ¹⁾	1097238 ¹⁾	
Type	8406	8506	8506	8507	
Operating principle/identification	Mechanical opening/closing				
Test load F _{max}	50	100	150	250	kN
Dimensions					
Height	146	176	176	252	mm
Width	385	371	416	522	mm
Depth	115	115	140	158	mm
Depth with stop strip	135	135	159	-	mm
Gripping area					
Height	80	80	80	100/120	mm
Width	60	60	60	80	mm
Gripping of the specimen	The specimen must be gripped with at least 1/2 of the jaw height.				
Gripping travel	8	8	8	8	mm
Specimen dimensions					
Flat specimen, thickness	0 ... 42	0 ... 42	0 ... 42	0 ... 64	mm
Round specimen, Ø	4 ... 30	4 ... 30	4 ... 30	4 ... 80	mm
Weight per specimen grip, approx.	37	44	49	108	kg
Connection, stud	Ø 36	Ø 60	Ø 60	Ø 60	mm
Ambient temperature	-55 ... +250 ²⁾	-55 ... +250 ²⁾	-55 ... +250 ²⁾	-55 ... +250 ²⁾	°C
Scope of delivery	2	2	2	2	piece(s)

1) Recommended and approved for strain rate control to standards DIN EN ISO 6892-1:2009 and ASTM E8-09

2) The temperature range may be limited by a smaller jaw temperature range.

CTA: 29570 29572

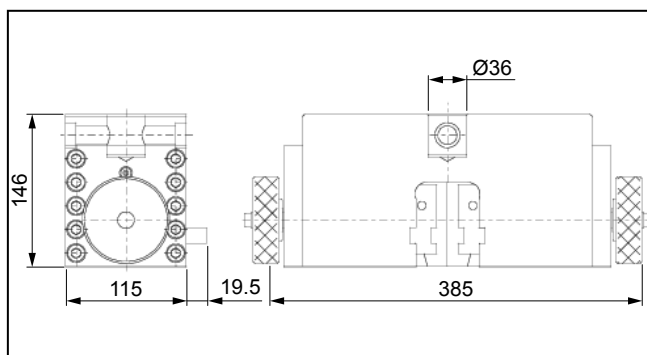

Type 8406 wedge screw grips (manual), F_{max} 50 kN: general view

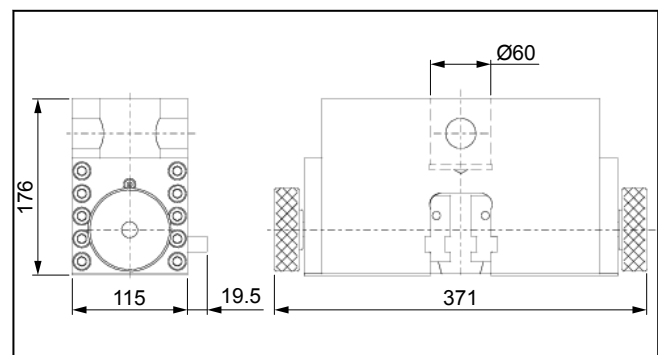

Type 8506 wedge screw grips (manual), F_{max} 100 kN: general view

Product Information

Wedge screw grips Type 8406 Fmax 50 kN, Type 8506 Fmax 100 kN, 150 kN and Type 8507 Fmax 250 kN, manual

CTA: 29574 29576

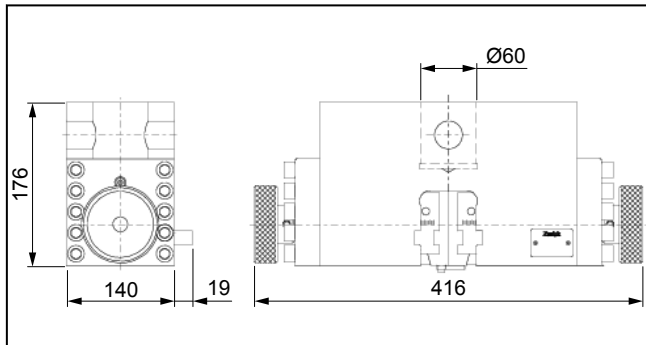

Type 8506 wedge screw grips (manual), Fmax 150 kN: general view

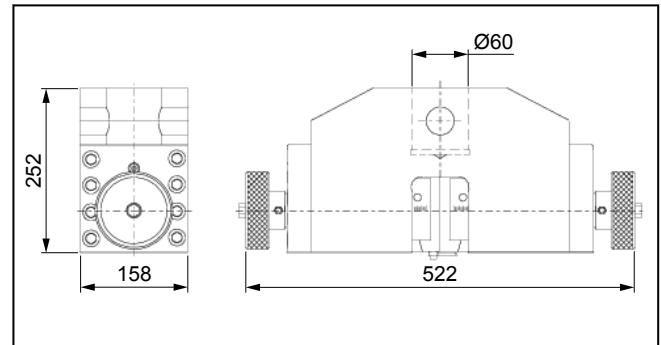

Type 8507 wedge screw grips (manual), Fmax 250 kN: general view

Accessories required

Flat jaws for type 8406 / 8506

Application	Version	Specimen dimensions		Gripping area		Ambient temperature [°C]	Hardness	Item No.
		Flat specimen, thickness [mm]	Round specimen, Ø [mm]	Height [mm]	Width [mm]			
Metal, wood, fiber-reinforced plastics	Steel, fsc ¹⁾ 0.4	0 ... 42	1 ... 4	80	60	-70 ... +250	61 HRC	316903
Metal, wood, fiber-reinforced plastics	Steel, fsc ¹⁾ 0.75	0 ... 42	2 ... 4	80	60	-70 ... +250	61 HRC	316905
Metal, wood, fiber-reinforced plastics	Steel, fsc ¹⁾ 1.25	0 ... 42	-	80	60	-70 ... +250	61 HRC	316907
Clamp-sensitive material	Steel, diamond-coated	0 .. 30	0 ... 13	80	60	-15 ... +80	-	317388
High-strength wires, glass fiber-reinforced plastics, carbon fiber materials	Hard metal, Pr ²⁾ 0.7 mm	0 ... 13	1 ... 8	45	30	-40 ... +250	1250 HV	317392 ³⁾
Hard metals	Hard metal, Pr ²⁾ 0.7 mm	0 ... 13	1 ... 8	70	34	-70 ... +250	1250 HV	318643 ⁴⁾

1) Fsc = fish scale

2) Pr = pyramid grid

3) Required: Jaw mounting Pr 0.7 mm, gripping area 45 x 30 mm

4) Required: Jaw mounting

Product Information

Wedge screw grips Type 8406 Fmax 50 kN, Type 8506 Fmax 100 kN, 150 kN and Type 8507 Fmax 250 kN, manual

Prism jaws for type 8406/8506 (1x required)

Scope of delivery: 1 set (= 4 pieces)

Application	Version	Specimen dimensions Round specimen, Ø [mm]	Gripping area Length [mm]	Ambient temperature [°C]	Hardness	Item No.
Round specimens: Metal, wood, fiber-reinforced plastics	Steel, St ¹⁾ 1.5	4 ... 10	80 ²⁾	-70 ... +250	61 HRC	316913
Round specimens: Metal, wood, fiber-reinforced plastics	Steel, St ¹⁾ 1.5	10 ... 30	80 ²⁾	-70 ... +250	61 HRC	316915

1) St= saw tooth

2) Prism jaws (with V-slot), thus the clamping length is specified here

Jaw mounting for type 8406 / 8506

Description	Item number
Jaw mounting for hard metal jaws, Pr 0.7 mm, 45 x 30 mm (1 set = 4 pieces) ¹⁾	317390
Jaw mounting for hard metal jaws, Pr 0.7 mm, incl. centering stops, 70 x 34 mm (1 set = 4 pieces)	318645

1) F_{max} 50 kN

Flat jaws for type 8507

- 1x required (alternatively 1x prism jaws)
- Scope of delivery. 1 set (= 4 pieces)

Application	Version	Specimen dimensions Flat specimen, thickness [mm]	Gripping area Height [mm] Width [mm]		Ambient temperature [°C]	Hardness	Item No.
Metal, wood, fiber-reinforced plastics	Steel, fsc ¹⁾ 0.4	0 ... 64	100	80	-70 ... +250	61 HRC	318602
Metal, wood, fiber-reinforced plastics	Steel, fsc ¹⁾ 0.75	0 ... 64	100	80	-70 ... +250	61 HRC	318604
Metal, wood, fiber-reinforced plastics	Steel, fsc ¹⁾ 1.25	0 ... 64	100	80	-70 ... +250	61 HRC	318606
Clamp-sensitive material	Steel, diamond-coated	0 ... 64	100	80	-70 ... +250	-	318608
Hard metals	Hard metal, Pr ²⁾ 0.7 mm	0 .. 48	80	50	-70 ... +250	1250 HV	320034 ³⁾

1) Fsc = fish scale

2) Pr = pyramid grid

Product Information

Wedge screw grips Type 8406 Fmax 50 kN, Type 8506 Fmax 100 kN, 150 kN and Type 8507 Fmax 250 kN, manual

3) Required: Jaw mounting

Prism jaws (with V-groove) for type 8507

- 1x required (alternatively 1x flat jaws)
- Scope of delivery: 1 set (= 4 pieces)

Application	Version	Specimen dimensions Round specimen, Ø [mm]	Gripping area Length [mm]	Ambient temperature [°C]	Hardness	Item No.
Round specimens: Metal, wood, fiber-reinforced plastics	Steel, St ¹⁾ 1.5	4 ... 10	100 ²⁾	-70 ... +250	61 HRC	318610
Round specimens: Metal, wood, fiber-reinforced plastics	Steel, St ¹⁾ 1.5	10 ... 30	100 ²⁾	-70 ... +250	61 HRC	318612
Round specimens: Metal, wood, fiber-reinforced plastics	Steel, St ¹⁾ 1.5	30 ... 60	100 ²⁾	-70 ... +250	61 HRC	318614
Round specimens: Metal, wood, fiber-reinforced plastics	Steel, St ¹⁾ 1.5	40 ... 80	120 ²⁾	-70 ... +250	61 HRC	318616
Round specimens: Hard metals	Hard metal, Pr ³⁾ 0.7 mm	4 ... 10/10 ... 30	80 ²⁾	-70 ... +250	1250 HV	325572 4)5)

- 1) St= saw tooth
- 2) Prism jaws (with V-slot), thus the clamping length is specified here
- 3) Pr = pyramid grid
- 4) Scope of delivery: 8 pieces
- 5) Required: Jaw mounting

Jaw mounting for type 8507

Description	Item number
Jaw mounting for hard metal jaws, Pr 0.7 mm, incl. centering stops	320036
Jaw mounting for hard metal jaws, Pr 0.7 mm, for round specimens	325573

Optional accessories

Connectors Type 8406 / Type 8506

Description	Item number
T-slotted shoe-connector with Connectors with M28 x 1.5 thread for connecting Ø8, 20, 36 mm mounting studs or load cells, centering spigot, Ø 30 H7, for connecting mounting unit, mounting flange or Ø 60 mm mounting stud 2 pieces	320252
T-slotted shoe connector for load cell calibration, Fmax 100 kN, with hole Ø 64/48 mm, included in delivery: 2 pieces	029093

Product Information

Wedge screw grips Type 8406 Fmax 50 kN, Type 8506 Fmax 100 kN, 150 kN and Type 8507 Fmax 250 kN, manual

Connectors type 8507

Description	Item number
Connectors with M28x1.5 thread for connecting Ø 8, 20, 36 mm mounting studs or load cells, centering gauge, Ø 30 H7, for connecting mounting unit, mounting flange or Ø 60 mm mounting stud. Scope of delivery: 2 pieces	318600
Mounting stud, Ø 60 mm only used with connectors. For connecting additional accessories. Scope of delivery: 1 piece	314062

Mounting unit and mounting flange Type 8406 / Type 8506 / Type 8507

Description	Item number
Mounting unit for connecting flexure tables, upper anvil holders and compression test kits	314058
Mounting flange (Fmax 250 kN) for connecting flexure tables.	314060