

## Product Information

Type 8095 pneumatic grips, Fmax 20 N, with toggle valve with flexible mounting position

CTA: 39551 32900

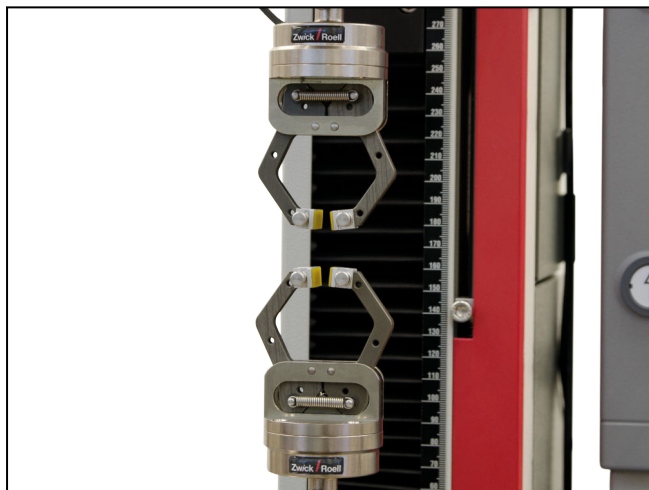

Pneumatic grips type 8095, Fmax 20 N, with flexible mounting options for control valve

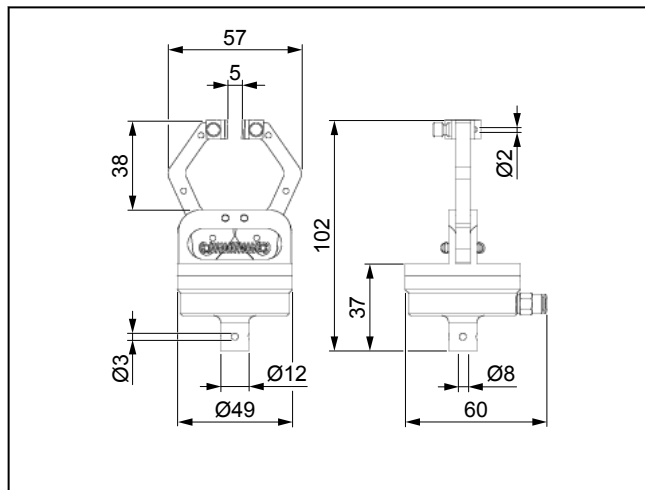

Pneumatic grips, type 8095, overview

### Applications

- Specimen material:  
plastics, textiles, paper, metals
- Specimen shape:  
round and flat specimens
- Type of loading:  
tensile

### Function description

Pneumatic grips are double acting and can be used for symmetrical gripping.

Pneumatic specimen grips are ideal for clamping-sensitive materials or if a high specimen throughput is required. The gripping force always remains constant, regardless of test load.

The gripping pressure for the specimen grip can be set steplessly and reproducibly via a pneumatic control unit and optionally via the testXpert III testing software. The specimen is held securely and jaw breaks are prevented during the test.

The specimen grip is opened and closed via buttons on the testing machine. The optional foot pedal unit or machine remote control can be used for additional operating convenience.

Double-actuator pneumatic grips always close symmetrically with respect to the tensile axis. This means the specimen is clamped in a precise axial position. It is not necessary to set the specimen thickness.

The jaws are secured with a threaded locking-pin, and can be changed without the use of tools.

An additional pneumatic control unit is not required. Soft opening and closing of the jaws takes place via a toggle valve. This offers advantages in terms of zero-force control.

The pneumatic gripping pressure on the grips cannot be changed. This is only possible by means of an additional pressure control valve.

### Advantages and features

- The symmetrically closing jaws save time required for adjusting to varying specimen thicknesses and ensure that the specimen is held exactly in the test axis.
- The jaws can be changed quickly and easily for different applications - no tools required. The jaws are centered automatically.
- Constant gripping force enables repeatable test results to be achieved.
- Constant pneumatic pressure allows even specimens prone to shrinkage to be held securely.
- Grips operated via toggle lever for fast, easy specimen changes.
- Ergonomic, open design for fast, easy specimen insertion and clamping

## Product Information

Type 8095 pneumatic grips,  $F_{max}$  20 N, with toggle valve with flexible mounting position

### Technical data

<b>Item No.</b>	<b>1106791</b>	
<b>Type</b>	<b>8095</b>	
Test load $F_{max}$	0.02	kN
Gripping force at 6 bar, approx.	115	N
Gripping force at 8 bar, approx.	150	N
Operating pressure, max.	8	bar
Dimensions		
Height	102	mm
Width	57	mm
Depth	60	mm
Opening width with jaws	5	mm
Gripping of the specimen	The specimen must be gripped with the entire height of the jaw.	
Weight per specimen grip, approx.	118	g
Connection, stud	Ø 8	mm
Ambient temperature	+10 ... +35	°C
Pneumatic connection (provided by the customer)	DN7 quick action coupling	
Scope of delivery	2 <sup>1)</sup>	piece(s)

1) Included in delivery: 2 toggle valves with flexible mounting position, with throttle check valve

### Accessories required

#### Pneumatic hoses (1x required)

Description	ArticleNumber
Set of pneumatic hoses for connecting a pair of pneumatic grips to a pneumatic control unit	<b>1 112640</b>



#### NOTE

If connected directly to the house line, a set of pneumatic hoses is not required.

#### Pneumatic control unit

See section 4.6 Accessories

## Product Information

Type 8095 pneumatic grips, Fmax 20 N, with toggle valve with flexible mounting position

### Jaws

Scope of delivery: 1 set (= 4 pieces)

Version	Specimen dimensions Flat specimen, thickness [mm]	Clamping surface		Ambient temperature [°C]	Hardness	Item No.
		Height [mm]	Width [mm]			
Vulkollan, smooth	0 ... 5	8	15	+10 ... +35	88 ± 3 Shore (A)	080491
Oxide ceramic, smooth	0 ... 5	15	10	+10 ... +35	Knoop 2300 N/mm <sup>2</sup>	080492