

Product Information

170 l/min. hydraulic power-pack

CTA: 52064



170-liter hydraulic power-pack without acoustic hood

Range of application

Series HP hydraulic power-packs were specially developed to cope with the demanding requirements of servo-hydraulic testing machines and testing systems. The power packs feature demand-dependent flow-rate control; delivery is at a constant pressure of 280 or 210 bar.

Description of operation

ZwickRoell Series HP power packs deliver high operational reliability combined with long service life, with all components mounted on top of the oil tank for easy access.

The self-priming radial-piston pump is driven by an asynchronous motor. The nine pistons are in hydrostatically balanced contact with the stroke ring. Flow rate is regulated by the stroke-ring eccentricity, which is adjusted via two control pistons located opposite each other. The pressurized oil is routed via a high-pressure filter and is then available to the appliance at output 'P'. A factory-set pressure relief valve prevents excessive increases in pressure.

The return oil is routed to the rear part of the tank via a low-pressure filter. A dedicated cooling circuit pump supplies oil to the oil-water heat-exchanger and returns it to the tank. A temperature-controlled valve switches the coolant water flow on and off. To prevent cavitation

a degassing filter is located in the tank, while an oil mist filter cleans air vented from the tank.

Advantages and features

- Variable-capacity pump automatically adjusts, consuming only sufficient electrical power to maintain the required flow at any given moment.
- 9-piston pump delivers an oil flow with minimal pressure fluctuations.
- Power packs have multiple vibration isolation.
- All connections, including pressure filter, feature operator-friendly front mounting.
- Integrated oil collection pan catches minor drips and leakages during hose and filter changes.
- Power packs are multiple-operation-ready, allowing an additional power pack to be connected if required.
- Modern power-pack control with SPS for convenient operation, including monitoring and status display.
- Wide range of monitoring functions available, including oil pressure, oil level, oil temperature, filter.
- Power pack can be operated either directly from the electrical cabinet or by remote control from the test stand (optional).
- The power packs are supplied ready for fitting of an acoustic hood. This can also be retrofitted.
- Vibration stabilizer can be retrofitted in order to damp disruptive vibrations in pipework installations where necessary.

Product Information

170 l/min. hydraulic power-pack

CTA: 52070 52071

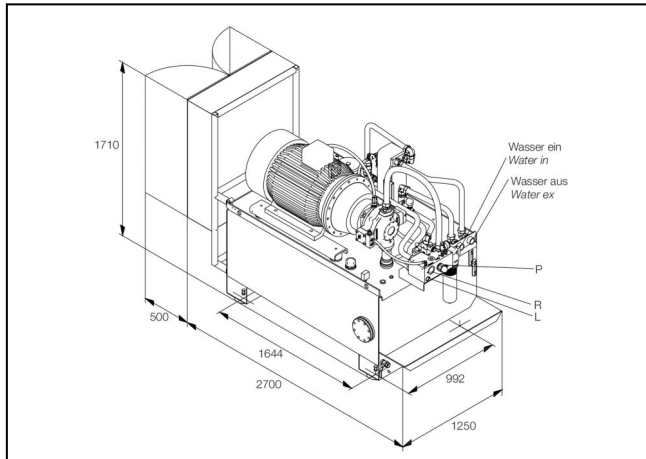

170-liter hydraulic power-pack

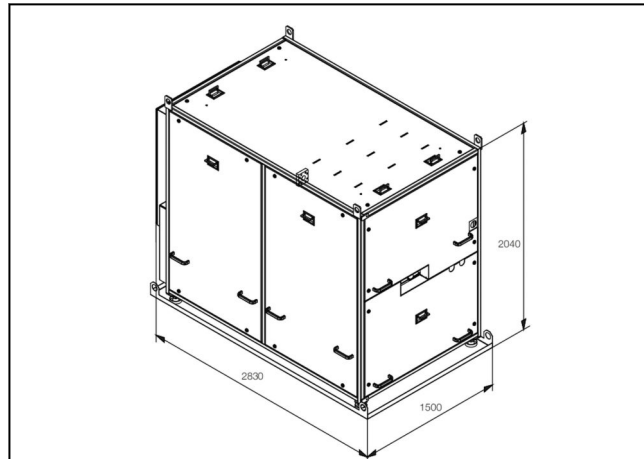

170-liter hydraulic power-pack with acoustic hood

Technical data

System pressure	210	280	bar
Item No.	068882	029981	
Nominal flow-rate	170	170	l/min
Oil temperature range	40...60	40...60	°C
High-pressure filter to ISO 16889, absolute	3	3	µm
Oil reservoir max. volume	1240	1240	l
Noise level (distance approx. 1 meter)	82	82	dB(A)
Motor output at nominal flow rate	73	95.5	kW
Electrical supply ¹⁾	400, 3PH/N/PE, 50 Hz	400, 3PH/N/PE, 50 Hz	V
Wire cross-section (up to 35m cable length)	4 x 70	4 x 95	mm ²
Fuse protection provision by customer	160	200	A
Protection class	IP 55	IP 55	
Weight (including oil)	3150	3150	kg
Hydraulic connections for:			
P (high pressure)	G 1 1/4"	G 1 1/4"	BSP P
R (return flow)	G 1 1/2"	G 1 1/2"	BSP P
L (leak oil)	G 1"	G 1"	BSP P
Radiated heat loss	8.4	11	kW
Coolant water req. at 25°C	90	120	l/min
Coolant water supply connection (inlet/outlet)	G 1 1/2" / G 1 1/2"	G 1 1/2" / G 1 1/2"	
Oil types	HLP-46 or HVLP-46	HLP-46 or HVLP-46; suggest Mobil DTE 25	

¹⁾ Alternative supply voltages and frequencies (60 Hz) available on request