

Product Information

Servo-hydraulic Testing Machine HC50/100 Compact

CTA: 221214 221072



HC50/100 Compact

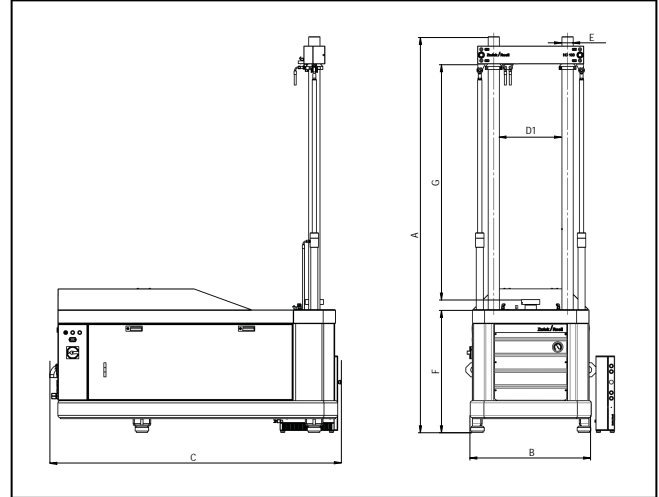

Drawing: HC50/100 Compact

Application

The HC Compact is a complete testing system with extremely small space requirement. The low noise power pack serves as the substructure for the test frame and the optional temperature chamber. With a testing actuator mounted in the lower crosshead, this testing machine is suitable for static and dynamic tests of all types up to 100kN. For LCF tests, as well as static and dynamic composites testing, the load frame features a particularly stiff design and can be equipped with an optional alignment fixture. All relevant static test fixtures for composites, including temperature chambers and extensometers, can be integrated in the machine. This makes it the composites testing machine par excellence.

Function description

The two-column load frame is bolted directly to the hydraulic power pack, and is designed so that no additional sound insulation measures of any type are required. Even for transport, the hydrostatic actuator is never separated from the system, whether mechanically or hydraulically. This is not even necessary when the load frame has to be separated from the hydraulic power pack due to reduced room height during installation—significantly reducing system commissioning costs. In addition to water cooling, the hydraulic power pack has an internal cooling circuit, which reduces the escape of heated air from the hydraulic power pack to a minimum. Therefore, there is much less heated air in the room and the HC Compact can be set up in almost any laboratory.

For maintenance purposes, the covers for the hydraulic power pack can be removed in a few simple steps.

All relevant components are arranged in such a way that they can be easily accessed by service personnel. The entire testing system, including the hydraulic power pack, is carried on anti-vibration leveling elements. With a total weight of approximately 1400 kg, it can be set up on almost any industrial floor. The load cell can be attached to the table top or the piston rod, depending on the type of test.

The frame features extremely precise alignment. Following installation of the testing actuator and load cell, alignment accuracy is $+0.1$ mm per meter separation; at distances below 350 mm the offset is constant at 0.05 mm. Plane-parallelity of mounting surfaces is equal to or better than 0.03 mm per 100 mm. All fixtures and ZwickRoell load cells are mounted via flanges with a centering gauge. An alignment fixture is also optionally available in the product range.

Advantages and features

- Space-saving testing system with integrated hydraulic power-pack
- Extra-quiet low-noise power pack
- The entire test, together with setup and control of automatic extensometers and specimen grips, is run via the display-equipped remote control
- Two-column frame for dynamic tests up to 100 kN with testing actuator installed in lower crosshead
- Suitable for 50 kN and 100 kN axial actuators
- Safety housing for compliance with CE Machinery Directive, depending on application
- Hydrostatic-bearing, sealless actuator for virtually frictionless and maintenance-free operation

Product Information

Servo-hydraulic Testing Machine HC50/100 Compact

- Additional internal cooling circuit reduces the emission of heated air from the hydraulic power pack to a minimum
- No mechanical or hydraulic separation from the actuator for transport purposes saves in commissioning costs
- Option: hydraulic adjustment for easy positioning of upper crosshead
- Range of accessories: product range specifically coordinated for LCF and composites applications

Test area height	Standard	Extended by 500 mm ¹⁾	
Dynamic nominal force	50/100	50/100	kN
A – max. height of end of column (with alignment fixture)	2320 (2430)	2820 (2930)	mm mm
B – max. width	860	860	mm
C – max. depth	2000	2000	mm
D1 – distance between columns	445	445	mm
E – column diameter	80	80	mm
F – height of top edge of lower crosshead	872	872	mm
G – max. height of test area ²⁾	350 ... 1175	600 ... 1680	mm
K – total weight ³⁾	1700	1750	kg
Frame stiffness at 1000 mm crosshead separation	500	500	kN/mm
Connection dimension	Ø 105 mm, 12 x M10		
HC 100 – clamping/adjustment: hydraulic/hydraulic	1085595	1085611	
HC 50 – clamping/adjustment: hydraulic/hydraulic	3010277	3010276	

1) Required for use with temperature chamber

2) Distance between piston flange and lower crosshead with piston retracted

3) With oil and 100 mm testing actuator, no grips

Product Information

Servohydraulic Testing Machine HC50/100 Compact

Machine testing actuator

Double-rod cylinder with hydrostatic bearings, sealless, system pressure 280 bar, integrated piston transducer

Nominal force [kN]	Piston stroke [mm]	Connection dimension	Item No.
50	100	Ø 105 mm, 12 x M10	925059
100	100	Ø 105 mm, 12 x M10	925060

Hydraulic power pack – low noise

Noise level	<58	dB(A)
System pressure	280	bar
Nominal output	30	l/min
Volume, oil reservoir	160	l
Coolant water req. max.	30	l/min
Coolant water inlet temperature	15 ... 28	°C
Emitted heat	0,5	kW
Electrical connection	400, 3PH/N/PE, 50 Hz ¹⁾	V
Motor power rating	15	kW
Item No.	3009244	

1) Or: 440 V, 3PH/N/PE, 60 Hz

Load cell

Nominal force [kN]	Accuracy class 1 ¹⁾ (N)	Item No.
50	≥ 200	1075285
100	≥ 400	1075286

1) to ISO 7500-1

Accessories

Description	ArticleNumber
Piston rod anti-rotation lock for HC frames	056357
Torque support	925041
Specimen grip control unit for HC50/100 Compact	3009248
Valve switching for two servo valves	3010114
Oil filling for hydraulic power pack	3007899

Safety device

Aluminium profile section construction with Makrolon panels, safety door at front, electrically monitored and interlocked.

Frame height	Standard	Extended by 500 mm
Safety device, four-sided	3010265	-
Safety device, three-sided, in conjunction with a temperature chamber	-	3010266
Simple protective pane		3010113